



Your ATA

- [Your New ATA, on page 1](#)
- [Devices Associated with Your ATA, on page 1](#)
- [Cisco ATA 191 and ATA 192 Hardware, on page 2](#)
- [Install Your New ATA, on page 6](#)
- [Phone Adapter Configuration Utility, on page 7](#)
- [Supported ATA Call Features, on page 8](#)

Your New ATA

Your analog telephone adapter (ATA) allows you to connect an analog device, such as an analog phone or fax machine, to your network. The connected device can then function like the IP phones in your network.

Your new analog telephone adapter (ATA) has two interfaces:

- Two RJ11 ports for analog devices
- A RJ45 port for Ethernet

Light-emitting diodes (LEDs) on the ATA provide status.

Install your ATA with the components that are included in the box.

You'll perform these tasks:

- Install your ATA with the components in the box.

Devices Associated with Your ATA

Use your ATA to connect these types of devices to your network:

- Analog phones
 - Analog phones have no softkeys.
 - The information that analog phones display depends on the model you have.
 - You use the phone's flash button for hold, resume, transfer, and conference.

- Analog telephony voice devices
 - The ATA supports analog telephony voice devices, such as overhead paging adapters and answering machines, that emulate a regular phone.
- Overhead paging systems
 - Overhead paging systems provide alarms and public-address announcements in buildings.
- Fax machines
 - Use a fax machine directly with an ATA. Don't connect an extension to a fax machine, and don't use the fax machine with a splitter.
 - To reduce fax failures, use overseas mode, if available; if not, set the fax machine transmission speed to low.
 - Data devices, such as facsimile machines and modems, may not function optimally. For the best fax and modem performance, continue to use a dedicated PSTN line.

Cisco ATA 191 and ATA 192 Hardware

The ATA 191 and ATA 192 are compact, easy to install devices.

The unit provides these connectors:

- 5V DC power connector.
- Two RJ-11 FXS (Foreign Exchange Station) ports—Your ATA has two RJ-11 ports that work with any standard analog phone device. Each port supports either voice calls or fax sessions, and both ports can be used simultaneously.
- One WAN network port—An RJ-45 10/100BASE-T data port to connect an Ethernet-capable device to the network.

The ATA 192 includes an extra LAN Ethernet port—An RJ-45 10/100BASE-T data port to connect to a device on your network, such as a computer, using an Ethernet cable.



Note The ATA network port performs autonegotiation for duplex and speed. It supports speeds of 10/100Mbps and full-duplex.

ATA 191 and ATA 192 Top Panel

The following figure shows the different LEDs and buttons found on the top of your ATA.

Figure 1: ATA 191 and ATA 192 Top Panel

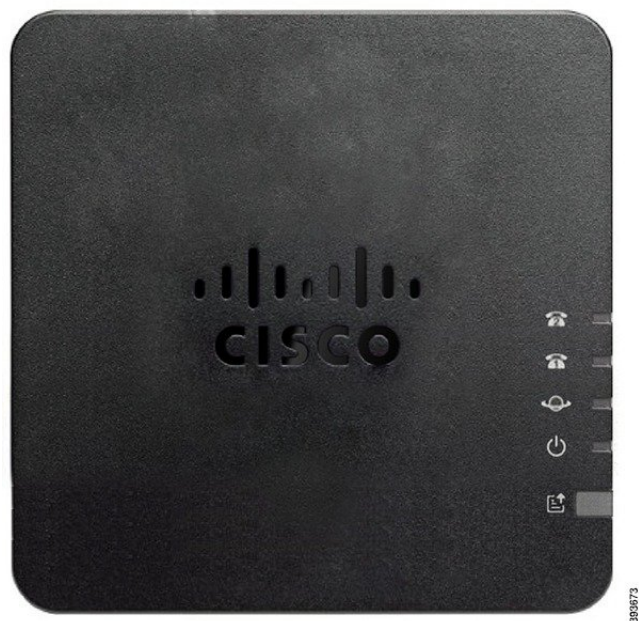





Table 1: ATA 191 and ATA 192 Top Panel Items

Item	Description
Power LED 	<p>Steady green: System booted up successfully and is ready for use.</p> <p>Slow flashing green: System is booting up.</p> <p>Fast flashing green three times, then repeats: System failed to boot up.</p> <p>Fast flashing green: The LED behaviour occurs in the following situations:</p> <ul style="list-style-type: none"> • System detects a factory reset. <p>To perform a factory reset, press and hold the RESET button for about 10 seconds.</p> <ul style="list-style-type: none"> • A factory reset is performed successfully. <p>Off: Power is off.</p>
Network LED 	<p>Flashing green: Data transmission or reception is in progress through the WAN port.</p> <p>Off: No link.</p>

Item	Description
Phone 1 LED Phone 2 LED 	<p>Steady green: On hook.</p> <p>Slow flashing green: Off hook.</p> <p>Fast flashing green three times, then repeats: The analog device failed to register.</p> <p>Fast flashing green: A factory reset is performed successfully.</p> <p>Off: The port is not configured.</p>
Problem Report Tool (PRT) Button	<p>Press this button to create a problem report using the Problem Report Tool.</p> <p>Note This button is not a power button. When you press this button, a problem report is generated and uploaded to a server for the system administrator.</p>
Problem Report Tool (PRT) LED 	<p>Flashing amber: The PRT is preparing the data for the problem report.</p> <p>Fast Flashing amber: The PRT is sending the problem report log to the HTTP server.</p> <p>Solid green for five seconds, then off: The PRT report was sent successfully.</p> <p>Fast flashing green: A factory reset is performed successfully.</p> <p>Flashing red: The PRT report failed. Press the PRT button once to cancel the flashing, then press again to trigger a new PRT.</p>

Problem Report Tool Button

The Problem Report Tool (PRT) button is on the ATA top panel. Press the PRT button, and a log file is prepared and uploaded to the server for troubleshooting your network.

You can instruct your analog phone users to press the PRT button on the ATA device to start the PRT log file process.

One of the following must be completed to upload the PRT log file from the ATA:

- Set up the HTTP server to upload the PRT log file from the ATA.
- Configure the customer support upload URL to best suit your needs, and apply it to the ATA.

ATA 191 and ATA 192 Back Panel

The following figures shows the different ports and buttons found on the back of your ATA.

Figure 2: ATA 191 Back Panel



Figure 3: ATA 192—Back Panel



Table 2: ATA 191 and ATA 192 Back Panel Items

Item	Description
RESET	<p>To restart the ATA, use a paper clip or similar object to press this button briefly.</p> <p>To restore the factory default settings, press and hold for about 10 seconds.</p> <p>The LED behaviour for the factory reset:</p> <ol style="list-style-type: none"> 1. After you press and hold the button for about 10 seconds, the Power LED is fast flashing green. 2. After the factory reset is performed successfully, all LEDs are fast flashing green for about 5 seconds.
PHONE 1	Use an RJ-11 phone cable to connect an analog phone or fax machine.
PHONE 2	Use an RJ-11 phone cable to connect a second analog phone or fax machine.
ETHERNET (ATA 192 only)	Use an Ethernet cable to connect your ATA to a device on your network, such as a computer.
NETWORK	Use an Ethernet cable to connect to the network.
DC 5V POWER	Use the power adapter that was provided to connect to a power source.

Install Your New ATA

Your ATA comes with everything to power it up, connect it to the network, and set it up on your desk.

Before you begin

Before you begin the installation, make sure you have the following equipment:

- Ethernet cable to connect to your network.
- Analog phone or fax machine to connect to your ATA.
- Phone cable to connect your phone.
- Uninterruptible power supply (UPS) to provide backup power.

Procedure

Step 1 Connect the network cable to your network and to the NETWORK port on the ATA.

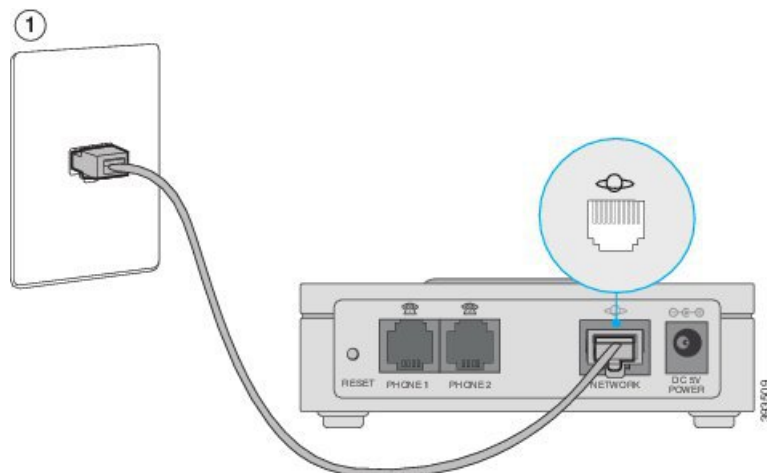

Step 2 Connect the phone cable to the PHONE 1 port on the ATA and to your analog device (phone or fax machine).

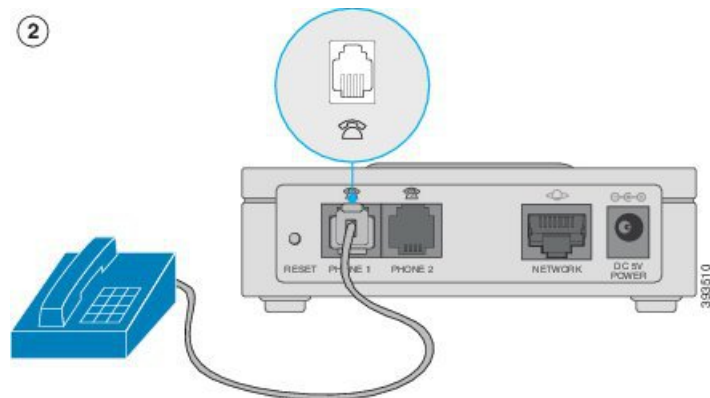

If connecting a fax machine, connect it directly to the ATA. Do not connect an extension to a fax machine, and do not use a splitter.

- Step 3** (Optional) If you have a second analog device, connect the phone cable to the PHONE 2 port on the ATA and to your second analog device.
- Step 4** Connect the ATA power cable to the DC 5V POWER port on the ATA, and plug the power cable into your power source.

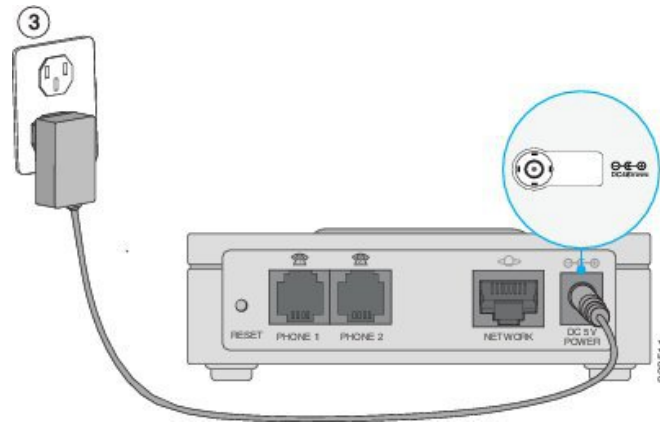

Phone Adapter Configuration Utility

You can configure or customize some phone features with the Phone Adapter Configuration Utility webpage. Your administrator gives you the page URL, your user ID, and password.

In the Configuration Utility page, you can view some network and administration settings, as well as some basic information about your ATA, such as firmware version, serial number, and memory use.

Most people use the Phone Adapter Configuration Utility page to set up a few basic features such as Speed dial or Call forward. To set up these features, refer to the following table.

The following table describes the phone features that you configure from the Phone Adapter Configuration Utility webpage.

Table 3: Configuration Utility Features

Feature	Description
Call forward and Selective call forward.	<p>You specify the number that will receive calls when call forward is enabled on the phone. Use the Configuration Utility page to set up more complicated call forward functions, for example, when your line is busy.</p> <p>For more information, see Call Forward Settings or Selective Call Forward Settings and Set Up Phone Features with Phone Adapter Configuration Utility.</p>

Feature	Description
Speed dial.	You assign phone numbers to a line so that you can quickly call that person. For more information, see Speed Dial Settings and Set Up Phone Features with Phone Adapter Configuration Utility
Supplementary services.	Configure such features as Call waiting, Do not disturb, or Called ID. For more information, see Supplementary Service Settings and Set Up Phone Features with Phone Adapter Configuration Utility
Distinctive ring	You can assign a specific ring to a phone number or line. For more information, see Distinctive Ring Settings and Set Up Phone Features with Phone Adapter Configuration Utility .
Ring setting	You can assign a specific ring to a certain situation such as when a call is on hold or during a call back. For more information, see Ring Settings and Set Up Phone Features with Phone Adapter Configuration Utility .

Supported ATA Call Features

Depending on your system configuration, your ATA supports some or all the following call features:

- Transfer (attended or supervised)—In this type of transfer, you talk to the receiving party before you complete the transfer.
- Transfer (unattended or unsupervised)—In this type of transfer, you complete the transfer and hang up before the receiving party answers.
- Conference.
- Hold and Resume.
- Caller ID.
- Call Waiting.
- Call Pickup.
- Speed Dial.
- Music On Hold.
- Shared Lines.

- Voicemail—This feature has no visual indicator, but a message waiting tone when you go off-hook indicates that you have voice messages. Some analog phones with a large LCD screen may display a voicemail icon.
- Call Forward.
- Redial.

